

# EMERGENSEE<sup>™</sup> **POD**

**D80 LED - WEATHERPROOF SURFACE MOUNTED  
NON-MAINTAINED EMERGENCY LIGHT**

The EmergenSee<sup>™</sup> Pod combines a lifetime-warranted ultra bright LED with a Syclops<sup>™</sup> optical lens in a water-tight enclosure to deliver an unobtrusive, ultra bright source of illumination intended to alleviate panic and establish a safe, distinct and efficient egress path in the event of an emergency.

This award-winning product comes in an architecturally-pleasing compact design that can either be surface mounted onto a solid surface or easily retrofitted into an existing luminaire\*. It can be used in almost all general applications including offices, shopping centres, commercial properties, and residential buildings.



**SYNTHIUM**<sup>™</sup> nanotechnology is an advanced environmentally sustainable energy development that offers extended battery life, low cost of ownership, enhanced performance and improved safety.



# Technical Specifications

Item	Part Number	EMS-POD/B
	Description	D80 LED Surface Mounted Weatherproof IP65 Non-Maintained Emergency Light c/w Synthium™ Battery - Black Trim
Input	Voltage & Frequency	230VAC ; 50Hz
	Installation	Terminal block, 20mm <sup>2</sup> cable entry
Output	Light Source	High performance 5W LED with Syclops™ optical lens - lifetime warranty
	Mode of Operation	Non-Maintained
	Power Consumption	1 W (standby)
	Emergency Duration	> 120 minutes
Controls	Charger	16hr intelligent 3-stage charger with Synthium™ battery management system
	Protection	Overcharge, low voltage disconnect, overcurrent, short circuit
	Testing Facility	Manual test switch
	Indicators	Battery charger green LED
Physical	Battery	Synthium™ Lithium Iron Phosphate - 10 year design life
	Construction	Flame-retardant polycarbonate - Black
	Mounting	Surface mounted - ceiling, Suspended by rod, wire or chain (supplied by others)
	Dimensions L x W x H	180mm x 150mm x 60mm
	IP / IK Rating	IP65 / IK08
	Weight	1.0kg
	Warranty	5 years
Environment	Operating Temperature	1° to 40°C
	Relative Humidity	0 to 95%
Compliance	Standards	RCM / EMC, AS/NZS 2293, AS/NZS 60598.1
	AS/NZS 2293 Classification	C0 D80 C90 D80
Accessories	STAR™ Self-Test and Reporting	P/N: EMS-POD/B/ST
	DALI-compatible	P/N: EMS-POD/B/DL
	SYNECTIX™ RF Wireless	P/N: EMS-POD/B/RF
	Replacement Battery	P/N: BAT-POD: Synthium™ LiFePO <sub>4</sub>

NOTE: Product specifications subject to change without prior notice due to ongoing product improvement policy and changes to industry standards.

## Dimensions

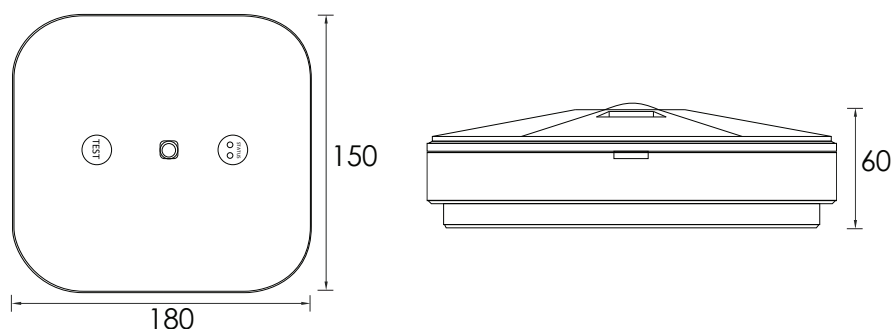

## AS/NZS 2293.1:2018 Spacing Table

SPACING TABLE	MOUNTING HEIGHT (m)								
NATA Classification	2.1	2.4	2.7	3.0	4.0	5.0	6.0	8.0	10.0
C0 - D80	11.5	13.2	14.8	16.5	22.0	27.5	28.9	30.9	32.1
C90 - D80	11.5	13.2	14.8	16.5	22.0	27.5	28.9	30.9	32.1

## Distributed By:

